



*Note: Safety labels removed for clarity.  
All guards and labels must be in place while operating.*

# Metering Hopper

## MODELS

### MH40 / MH80

# WEILER®

The Measurable Difference.

#### APPLICATION:

Designed to offer a dependable, versatile, safe and sanitary way to meter and transfer raw materials in a processing line. From whole muscle meats to pre-ground fresh meats, it provides an efficient way for metering raw materials to down-stream equipment.

#### FEATURES:

- Polished food contact surfaces reduce raw material smearing and lean/fat separation.
- Drop down, split-design trough cover allows for easy cleaning and requires lower head room.
- Hopper guard and trough cover are interlocked for safe operation and safe sanitation.
- Ribbed trough provides efficient transfer of raw materials.
- Eliminates manual raking of raw materials.
- Controls feed rate to maximize grinder performance.
- Removable hopper seal facilitates cleaning and maintenance.
- NEMA 4X enclosure with start/stop/clean/e-stop push button box is included. (Starter not included)
- Clean-mode provides a safe and reliable way to rotate screws for sanitation.
- Independent drives can accept variable speed for precise weight control.

# Metering Hopper MODELS MH40 / MH80

## SPECIFICATIONS:

### • DRIVE:

INCLINE SCREW: 10 HP (7.5 kw) Nord gear motor.

CROSS SCREW: 3 HP (2.2 kw) Nord gear motor.

• **CONSTRUCTION:** 304 stainless steel screws, tub and trough.

• **SCREW DIAMETERS:** INCLINE: 16" (400 mm); CROSS: 24" (600 mm).

• **HOPPER CAPACITY:** MH40: 40 cu.ft. (1133 liters); MH80: 80 cu.ft. (2266 liters).

• **WEIGHT:** MH40: Unskidded: 4500 lbs. (2140 kg); Skidded: 5000 lbs. (2268 kg).

MH80: Unskidded: 6000 lbs. (2722 kg); Skidded: 6500 lbs. (2948 kg).

*Note: Weight based on 12' unit and will vary with different length conveyors.*

• **OPTIONS:** • Right or left hand discharge configuration.

• Positive drive feed: 2 HP (1.5 kw) Nord gear motor.

• Stainless steel drive covers.

**DIMENSIONS:** Dimensions shown are for 12' length conveyors, and may vary depending on conveyor length.

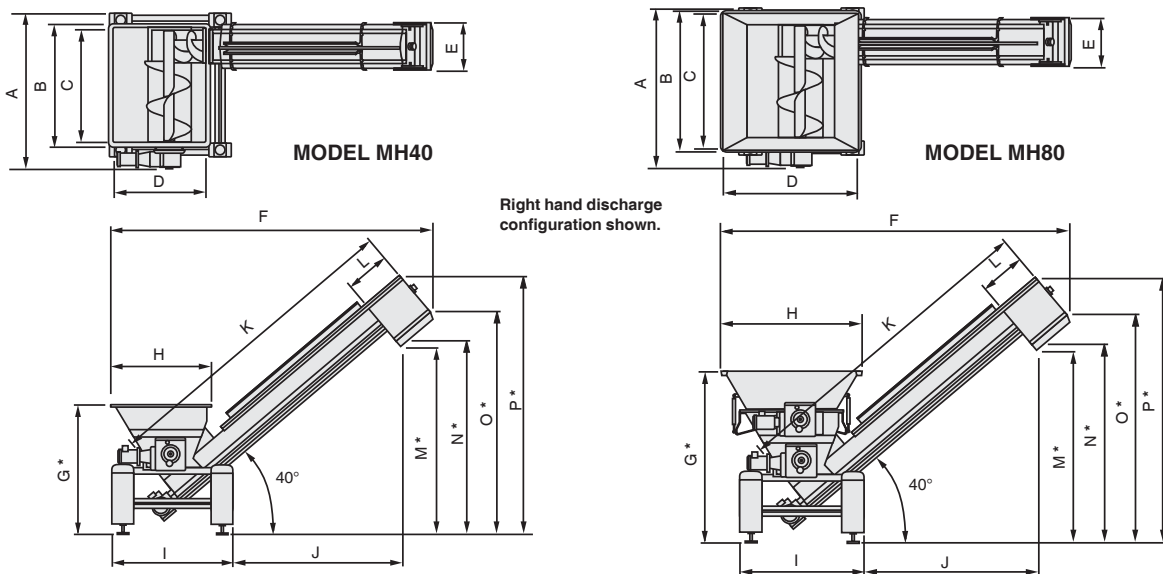

	A	B	C	D	E	F	G*	H	I	J	K	L	M*	N*	O*	P*
MH40	84 (2134)	66 (1676)	61 (1549)	49 (1245)	26 (660)	173 (4394)	70 (1778)	54 (1372)	65 (1651)	91 (2311)	168 (4267)	24 (610)	100 (2540)	104 (2642)	120 (3048)	138 (3505)
MH80	84 (2134)	75 (1905)	71 (1803)	70 (1778)	26 (660)	183 (4648)	90 (2286)	74 (1880)	65 (1651)	91 (2311)	168 (4267)	24 (610)	100 (2540)	104 (2642)	120 (3048)	138 (3505)

\* Up to 3" (76 mm) height adjustment (max).  
Dimensions shown are rounded in inches (mm).  
Dimensions and specifications subject to change without notice.

*Note: Dimensions shown should not be used for installation purposes.  
Please request a certified approval drawing from Weiler.*

**WEILER**<sup>®</sup>

The Measurable Difference.

www.weilerinc.com

USA: 800-558-9507 • Fax: 262-473-5867 • Europe: +44 (0) 1454 320900 • Fax: +44 (0) 1454 326262

Grinders • Mixers • Conveyors • Mixer Grinders • Separators • Complete Systems

BMH40-80-E-OCT05

**WEILER**<sup>®</sup>